

# Analysis of the Iowa Energy Center’s Independent Testing of the PICCV

By Brian Allen and Tricia Bruenn  
Belimo Aircontrols (USA), Inc.

## Objective:

The purpose of this report is to summarize the findings of the independent testing done by the Iowa Energy Center on Belimo’s Pressure Independent Characterized Control Valve (PICCV). The overall objective of the study was to evaluate the performance of the PICCV against conventional globe control valves for terminal reheat and chilled water cooling coil applications in a commercial office building. The facts are condensed into a user friendly format that will enable you to analyze and compare the performance of both valves on a heating and cooling system. All charts and findings come directly from the full report.

## Table of Contents:

### 1.0 Description of Pressure Independent Valve

- 1-1. Design
- 1-2. Function
- 1-3. Operation
- 1-4. Advantages

### 2.0 The Iowa Energy Center

- 2-1. The Facility
- 2-2. Testing Procedures
- 2-3. Schematic of Heating Water Loop and Instrumentation
- 2-4. Schematic of Chilled Water Loop and Instrumentation

### 3.0 Terminal Reheat Open Loop Test

- 3-1. Results
- 3-2. Conclusions

### 4.0 Terminal Reheat Closed Loop Test

- 4-1. Results
- 4-2. Conclusions

### 5.0 Air Handling Unit Chilled Water Open Loop Test

- 5-1. Results
- 5-2. Conclusions

### 6.0 Air Handling Unit Chilled Water Closed Loop Test

- 6-1. Results
- 6-2. Conclusions

### 7.0 Summary of the Results

- 7-1. Overall Results of the PICCV as they relate to HVAC Systems

## 1.0 Description of Pressure Independent Valve

### 1-1. Design



### 1-2. Function

The PICCV combines the functions of the automatic balancing valve and control valve which enables it to supply an accurate and stable flow while dynamically balancing the supply based on demand. The flow is held constant, but independent of system pressure fluctuations on the degree of ball opening, therefore the control valve is pressure independent at all inlet and outlet pressures because the differential is under control.

Where a standard valve is oversized at average to light loads (95-99% of operation) and may oscillate or hunt, the PICCV control valve has an equal percentage response curve under all conditions which results in a linearized heat emission with respect to the control signal.

This solution simplifies valve sizing and design, saves money in balancing and engineering time as well as labor in installation. All the disadvantages of variable flow systems are eliminated to represent the best hydronic solution for most HVAC applications.

### 1-3. Operation

**PICCV consists of a differential pressure regulator in series with a control valve.**

The amount of flow that passes through the valve is controlled by the use of a pressure regulator that moves according to the change in pressure above and below it.

All pressure changes are absorbed by the pressure regulator allowing the differential pressure to be held constant over the control valve section thereby giving the same flow.

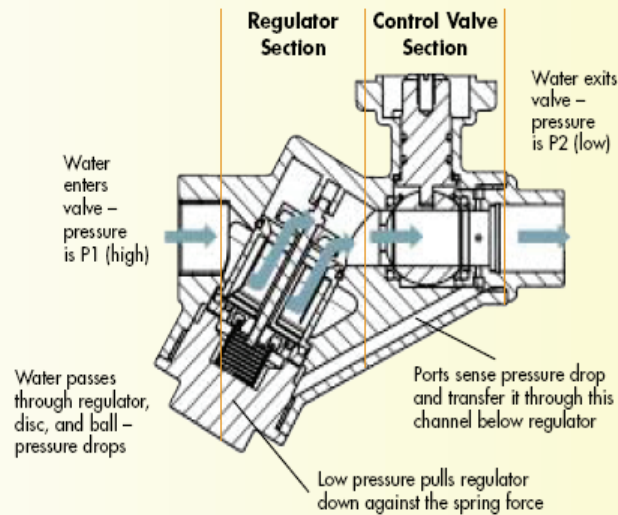

### 1-4. Advantages

- Easy selection, no Cv calculation required
- Hydronic balancing is simplified, as the circuits are not interactive
- Flexible commissioning
- One piece installation saves 50% of labor costs, installation space, and investment for balancing valve
- Reduces pumping costs
- Maintains  $\Delta T$  for higher efficiency of chillers and condensing boilers
- Visualizes flow in a BMS system and provides accurate flow for each degree of opening
- Prevents overflow or underflow for fast start-up

## 2.0 The Iowa Energy Center

### 2-1 Test Facility

Testing was performed at the Iowa Energy Center, Energy Resource Station. The Energy Resource Station (ERS) is known for researching cost effective, energy efficient technologies for commercial and industrial building performance with real-time, real-life conditions and on-line HVAC (heating, ventilation and air conditioning) systems. A schematic of the facility is shown in *Figure 2-1*. The facility consists of four matched pairs (“A” and “B”) of test rooms facing east, south, west and into the interior. Side A of each test room pair is isolated from side B and is served by a separate heating, ventilating and air-conditioning system. The paired rooms are identical in their construction and heating and cooling loads. This design enables side-by-side comparisons of the systems and/or the algorithms that control them. The test rooms are equipped with both overhead and perimeter heating and cooling systems. Additional information on the ERS, including an online virtual tour of the facility, can be viewed at the following web site: <http://www.energy.iastate.edu/ers/>.

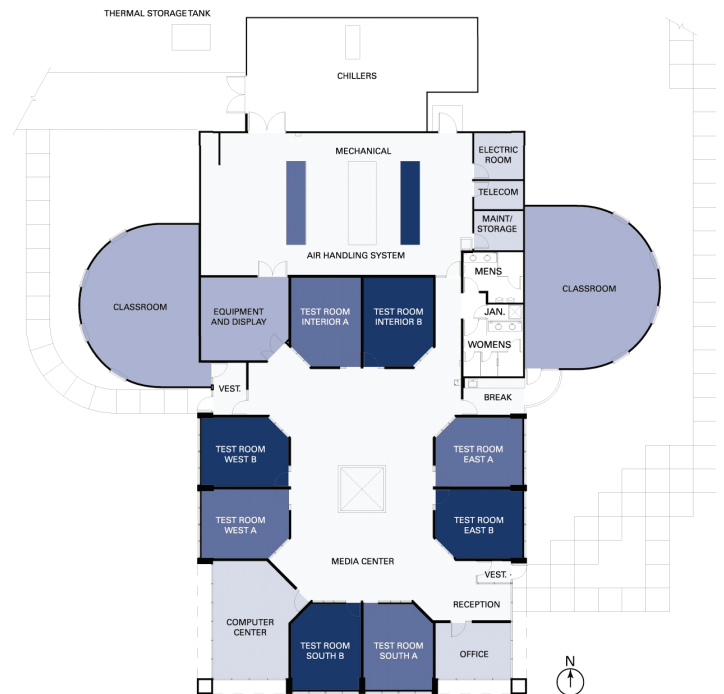

Figure 2-1: Schematic of the side-by-side test rooms of the Energy Resource Station.

## 2-2. Terminal Reheat Open Loop Test

The purpose of this suite of tests, which is designated Test Suite 1, was to evaluate the pressure independent feature of the Belimo PICCV. The test consisted of measuring the water flow rate through the test valve as a function of valve position and pressure drop across the valve for a VAV terminal reheat application.

### Terminal Reheat Closed Loop Test – Effect of Valve Sizing on Valve Performance

The purpose of this suite of tests, which is designated Test Suite 2, was to compare the control performance of the Belimo PICCV to three conventional globe valves, each having a different flow coefficient ( $C_v$ ), for a VAV terminal reheat application. The conventional globe valves consisted of one correctly sized valve (the same valve used in the open-loop tests described in Chapter 2) and two oversized valves. The tests consisted of evaluating control characteristics, such as stability and ability to maintain the room or discharge air temperature at setpoint, as scheduled disturbances were imposed on the process being controlled.

### Air-Handling Unit Chilled Water Open Loop Test

The purpose of this suite of tests, designated Test Suite 4, was to evaluate the pressure independent feature of the Belimo PICCV for an AHU chilled water cooling coil application. The tests mimicked Test Suite 1, which were performed on smaller terminal reheat valves. Like Test Suite 1, the tests described here consisted of measuring the water flow rate through the test valve as a function of valve position and pressure drop across the valve.

### Air-Handling Unit Chilled Water Closed Loop Test – Control Performance

The purpose of this suite of tests, which is designated Test Suite 5, was to compare the control performance of the Belimo PICCV to a conventional globe valve for a chilled water cooling coil application. The test evaluated various control characteristics, such as stability and ability to maintain the supply air temperature at the setpoint, as scheduled disturbances were imposed on the cooling coil and control valve.

## 2-3. Heating Water Loop and Instrumentation

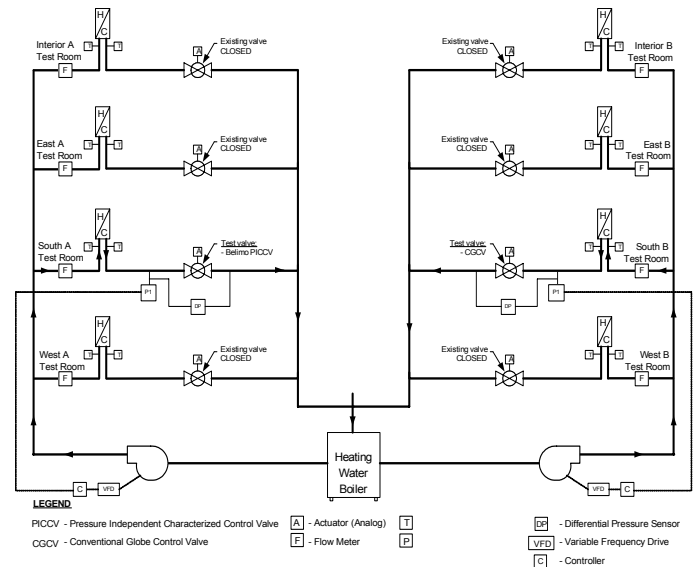

Figure 2-2 Schematic of heating water Loop-A and Loop-B and instrumentation setup for test

## 2-4. Chilled Water Loop and Instrumentation

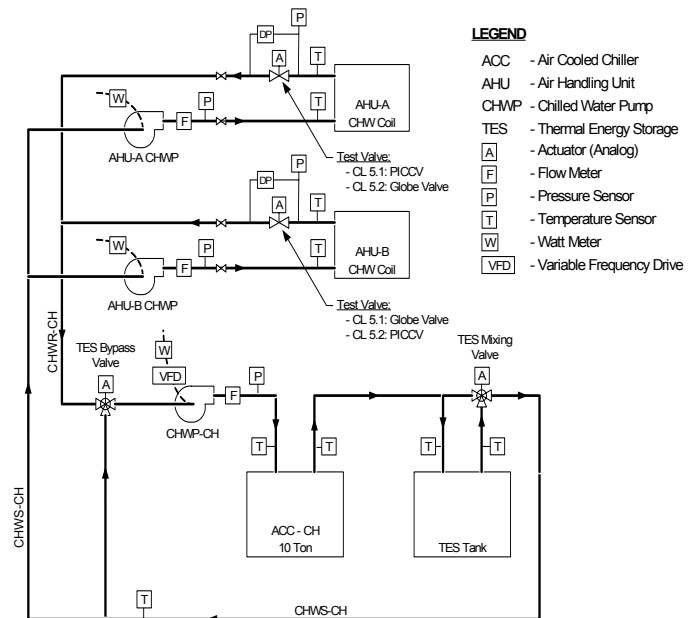
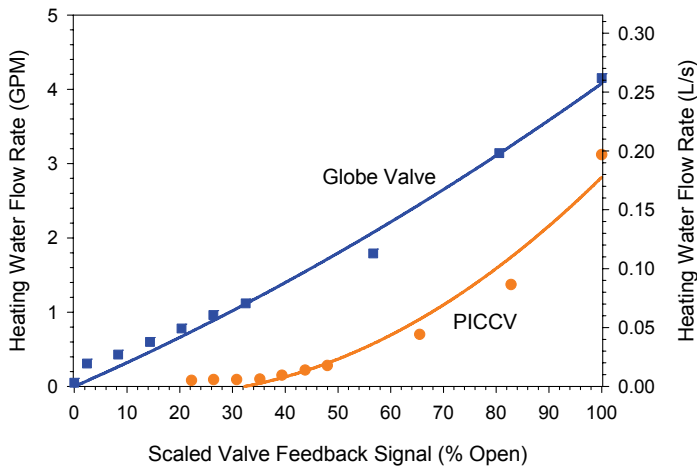

Figure 2-3: Schematic of chilled water system and instrumentation setup for test





#### 4-1. Results

In general, the Globe valves maintained the temperature being controlled, however, the globe valves also exhibited significantly greater actuator travel, number of reversals, and cumulative change in water flow rate in comparison to the Belimo valve.

Figure 4-1 shows the feedback position signal for the Belimo PICCV and the oversized globe valve. The globe valve actuates considerably more than the Belimo PICCV, as indicated by the greater thickness of the plotted data in Figure 4-1b in comparison to Figure 4-1a. The data shows that the actuator travel for the Globe valve is 2.5 times that of the Belimo PICCV. As a result, the flow rate through the Globe valve shows considerably more variability than the flow rate through the Belimo PICCV. The data reveals that the cumulative change in the water flow rate of the Globe valve is more than **six times higher** than that of the PICCV. The room temperature response in the two rooms is comparable, although the effect of the fluctuating water flow rate associated with the Globe valve can be seen in the room temperature response. The room airflow rate for the two test rooms, the inlet pressure to the control valves, and the entering air temperatures to the reheat coils are shown to demonstrate that these parameters were well controlled and did not contribute to differences in the performance of the test valves.

### 3-2. Conclusion for Terminal Reheat Open Loop Test

Open-loop tests were conducted to quantify the water flow rate through a Belimo PICCV-15-003 and a correctly sized Globe valve as a function of differential pressure across the valve and the commanded signal to the valve. Consistent with the manufacturer's literature, for a differential pressure range of 5 to 30 psi, the flow rate through the Belimo PICCV was nearly independent of differential pressure for a fixed valve position. As expected, the flow rate through the Globe valve increased as the differential pressure increased for a fixed valve position; however, the flow rate through the Globe valve with the valve fully open was 13 to 15% higher than expected based on the manufacturer's literature. Furthermore, the valve is oversized by approximately 21% based on sizing that is intended to produce a 4 psi pressure drop at the design flow of 3 GPM (0.19 L/s), and the valve is oversized by approximately 60% based on ASHRAE sizing criteria. Testing also revealed that the Belimo valve has an equal percentage characteristic curve, while the Globe valve has a nearly linear characteristic curve.

### 4.0 Terminal Reheat Closed Loop Test – Effect of Valve Sizing on Valve Performance

The purpose of this suite of tests, was to compare the control performance of the Belimo PICCV to three conventional globe valves, each having a different flow coefficient ( $C_v$ ), for a VAV terminal reheat application. The conventional globe valves consisted of one correctly sized valve (the same valve used in the open-loop tests) and two oversized valves. The tests consisted of evaluating control characteristics, such as stability and ability to maintain the room or discharge air temperature at setpoint, as scheduled disturbances were imposed on the process being controlled.

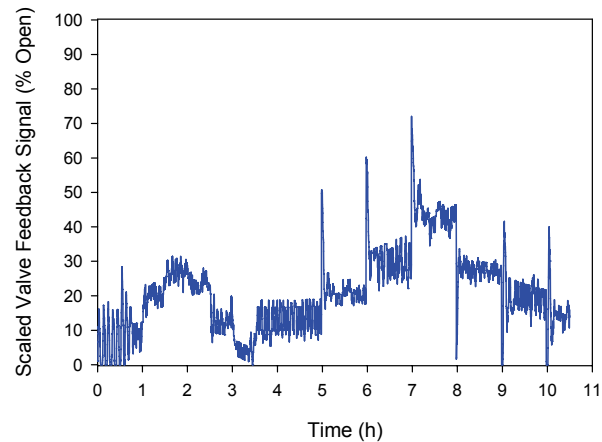
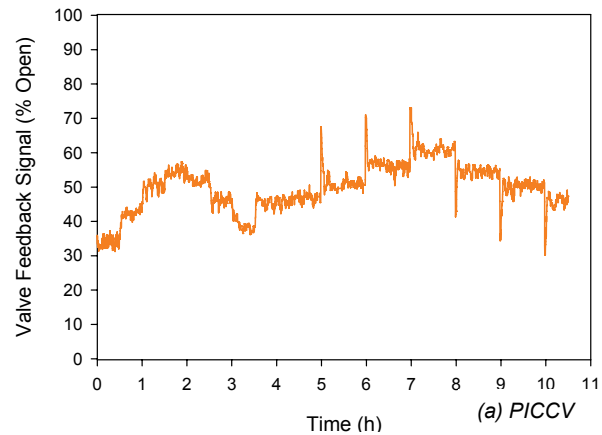

Figure 4-1. Valve position feedback signal

## Results

In this test the performance of the Belimo PICCV is compared to a correctly sized globe valve for a discharge air temperature control application with a constant inlet pressure to the control valve. This test was chosen because the inlet pressure for the Belimo PICCV is relatively unstable in comparison to the inlet pressure for the globe valve. This can be seen and results from unstable control of the Loop-B heating water pump that serves this valve. A more stable inlet pressure should make stable flow control more achievable. Thus, the conditions for this test favor the globe valve.

The feedback position of the valves is shown in *Figure 4-2*. The most interesting thing to note about the feedback position is the fact that the globe valve feedback indicates it is closed for the first 75 minutes of the test. During the next hour, the globe valve fluctuates between 0 and 5% open. As the test continues, the position fluctuations decrease as the valve opens further. By contrast, the Belimo PICCV position feedback signal does not fluctuate, indicating it provides more stable control despite the less stable inlet pressure conditions that it experiences.

The heating water flow rates for the valves are shown in *Figure 4-3*. Although the position feedback for the globe valve indicated it was closed for the first 75 minutes of the test, the water flow rate was nonzero during this period. Comparing the two plots, it is clear that the flow rate through the Belimo PICCV is more stable than that through the globe valve. Note that the cumulative change in the water flow rate for the globe valve (41.7 GPM) is approximately twice the value for the PICCV (22.1 GPM). In addition, the PICCV is able to provide stable flow even when the water flow rate is less than 0.2 GPM. Suffice it to say that the low load conditions that lead to such low flow rates are common in terminal reheat applications. For the current tests, the ability to deliver stable control at low water flow rates results in stable temperature control when the discharge air temperature setpoint is 60°F and 65°F.

By contrast, the globe valve produces a temperature response that fluctuates considerably at these low air temperature setpoints. Although discharge air temperature control is not the typical application for reheat coil valves, it is common for the valves to operate

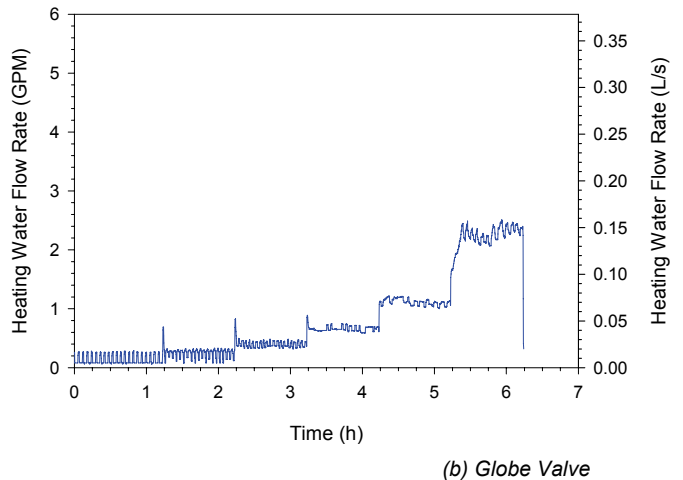
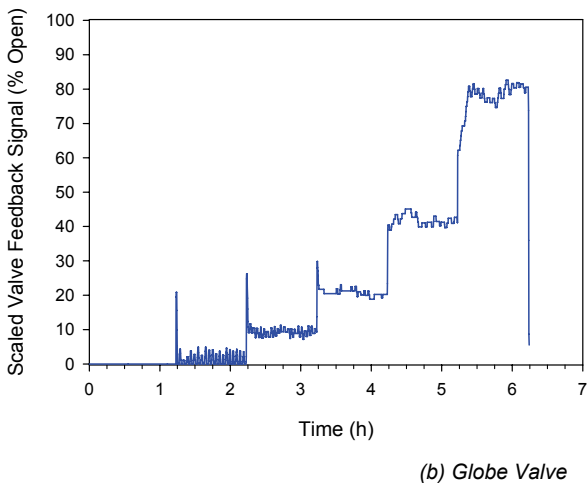
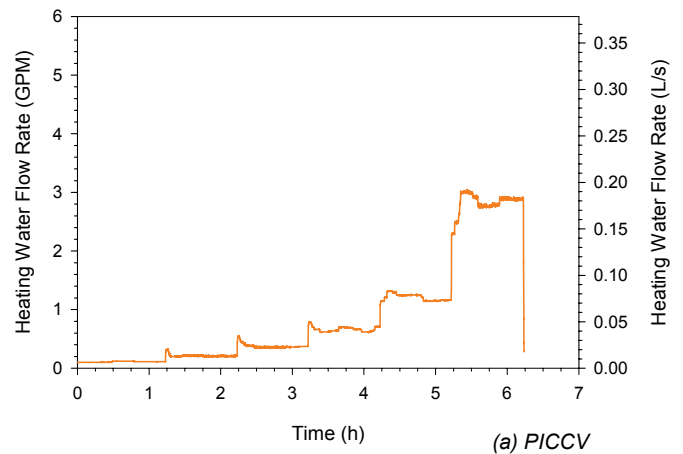
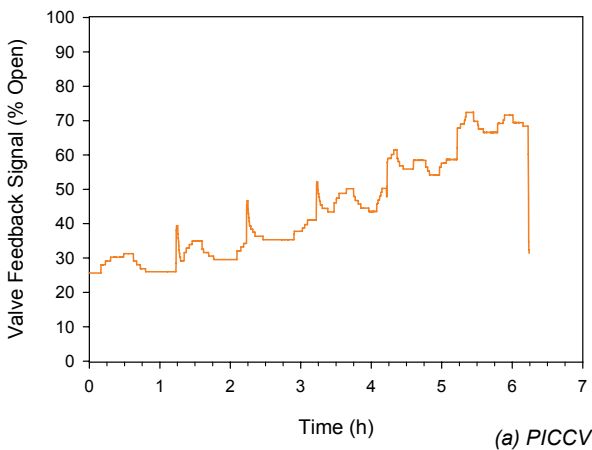

Figure 4-2: Valve position feedback signal.

Figure 4-3: Heating water flow rate.

at low heating water flow rates. If the valve is unable to deliver low flow rates, the room temperature response will tend to fluctuate as the valve “hunts” to find the correct flow.

Accumulated actuator travel, starts and stops, and reversals are plotted in *Figures 4-4 to 4-5*. Although water flow and discharge air temperature measurements indicate the globe valve is opening and closing while the discharge air temperature is controlled to 60°F, the feedback signal from the globe valve indicates it is closed during this time. As a result, the accumulated actuator travel, starts and stops, and reversals remain equal to zero for the globe valve until the setpoint is increased to 65°F. If the feedback signal for the globe valve reflected the actual operation of the valve at low flow rates, the disparity in actuator travel, starts and stops, and reversals would be even more pronounced than it currently is. Even so, the globe valve travel is approximately **2.8 times greater** than that of the Belimo valve, the starts and stops are approximately **2.5 times greater**, and the reversals are approximately **7 times greater**.

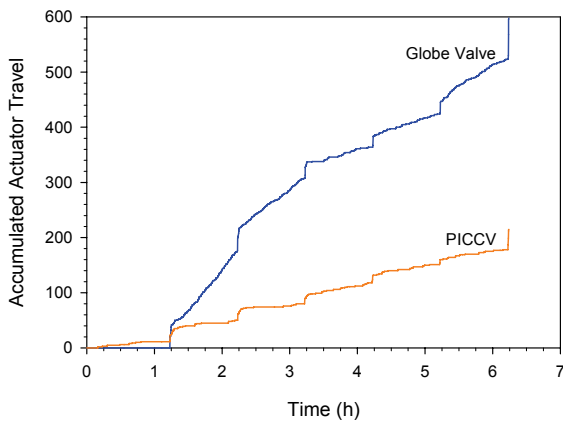

Figure 4-4: Accumulated actuator travel.

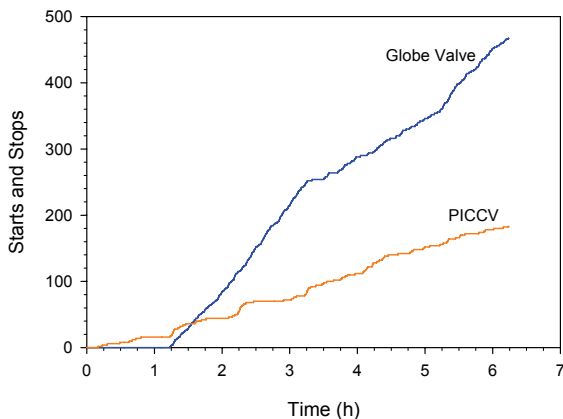

Figure 4-5: Accumulated starts and stops.

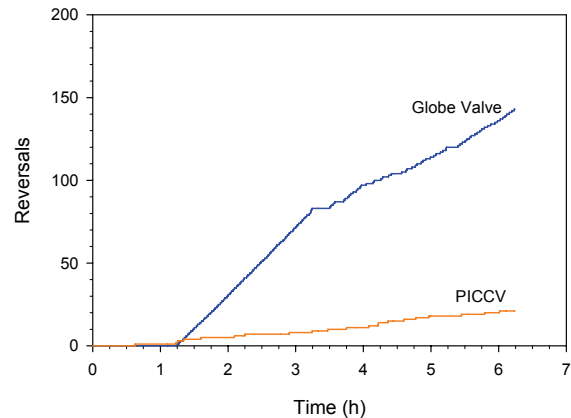

Figure 4-6: Accumulated reversals.

There is little difference in the temperature control between the Belimo and globe valves; however, the Belimo PICCV accomplishes the temperature control with approximately three times less actuator travel, approximately 20% fewer starts and stops, and approximately half as many reversals. Furthermore, the cumulative change in the water flow rate of the Belimo PICCV was **seven to eleven times less** than that for the globe valve.

## 4-2. Terminal Reheat Closed Loop

### Conclusions:

Closed-loop tests were conducted to quantify the control performance of the Belimo PICCV-15-003 and three Globe valves having different  $C_v$  values. The three Globe valves included a correctly sized valve (with  $C_v = 1.6$ ), an oversized valve (with  $C_v = 2.5$ ), and a very oversized valve (with  $C_v = 4.0$ ). Test Suite 2 was performed to exercise the valves and analyze how they performed over a broad range of conditions. Test Suite 2 consisted of the following: 1) room temperature control application with fixed inlet pressure to control valve and variable heating water loop pump speed; 2) discharge air temperature control application with fixed inlet pressure to control valve and variable heating water loop pump speed; and 3) room temperature control application with variable inlet pressure to control valve and constant heating water loop pump speed. Control performance was evaluated in terms of the temperature control, actuator travel, actuator starts and stops, actuator reversals, and the cumulative change in the water flow rate.

Actuator travel, actuator reversals, and the cumulative change in the water flow rate were consistently and significantly less for the Belimo valve in comparison to the globe valves. These results confirm what can be visually observed from plots of the valve feedback signals, flow rates through the valves, and temperature responses associated with the valves.

Specifically, the Belimo valve control was more stable than the globe valve control for the tests conducted and the tuning parameters utilized. The temperature control of the Belimo and globe valves was similar, with the exception being operation at low flow rates. The Belimo valve provided stable control under all test conditions and was capable of producing stable flow rates below 0.2 GPM (0.013 L/s). By contrast, the globe valve had difficulty providing stable flow at low flow rates and instead would tend to open and close periodically with resultant flow rates that fluctuated between 0 and 0.25 GPM. As a result, the temperature being controlled tended to fluctuate as well.

The impact of valve sizing on control performance was made especially apparent by considering the cumulative change in the water flow rate. This parameter, which represents the sum of the change in the water flow rate from the current sampling time to the previous sampling time, increased significantly as the flow coefficient of the globe valve increased and the valve authority decreased.

### 5.0 Air-Handling Unit Chilled Water Open Loop Test

The purpose of this suite of tests was to evaluate the pressure independent feature of the Belimo PICCV for an AHU chilled water cooling coil application. The tests mimicked Test 1, which were performed on smaller terminal reheat valves. Like Test 1, the tests described here consisted of measuring the water flow rate through the test valve as a function of valve position and pressure drop across the valve.

#### 5-1. Results

The curves in *Figure 5-1* reveal that the flow rate through the Belimo PICCV is nearly independent of the differential pressure across the valve for a given commanded signal to the valve. This result is consistent with findings reported for a smaller PICCV, and the performance expected based on Belimo literature.

#### Results

The water flow rate through the globe valve as a function of the differential pressure across the valve and the commanded signal to the valve is shown in *Figure 5-2*. The curves in *Figure 5-2* indicate that the flow rate through the globe valve increases as the differential pressure across the valve increases for a fixed commanded signal to the valve. This is consistent with the manufacturer's literature on this series valve; however, the flow rates measured when the valve was fully open are approximately 21% lower than expected based on the manufacturer's literature.

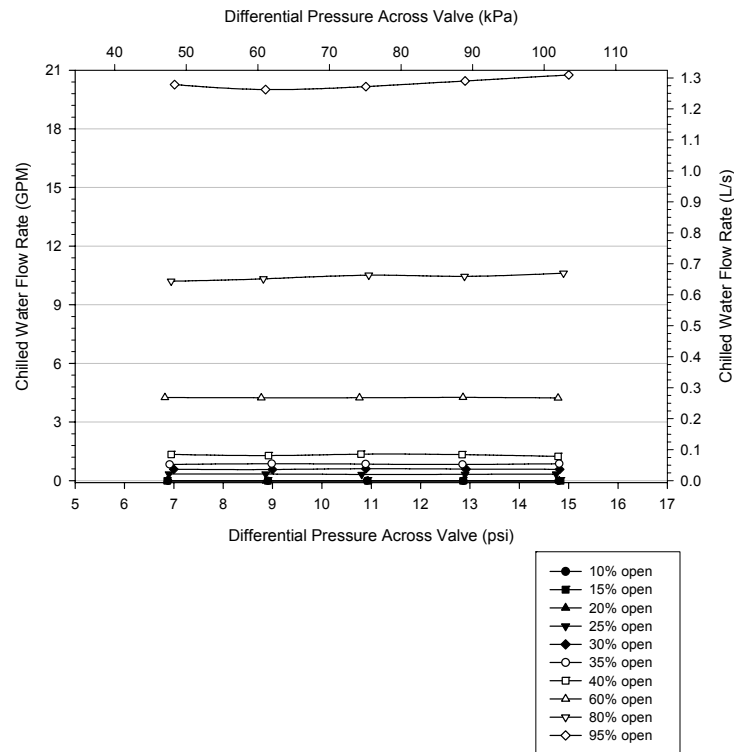

Figure 5-1: Flow rate through the Belimo PICCV as a function of differential pressure and commanded signal to the valve. (Chilled Water Cooling Coil Application – PICCV-32-026-PT)

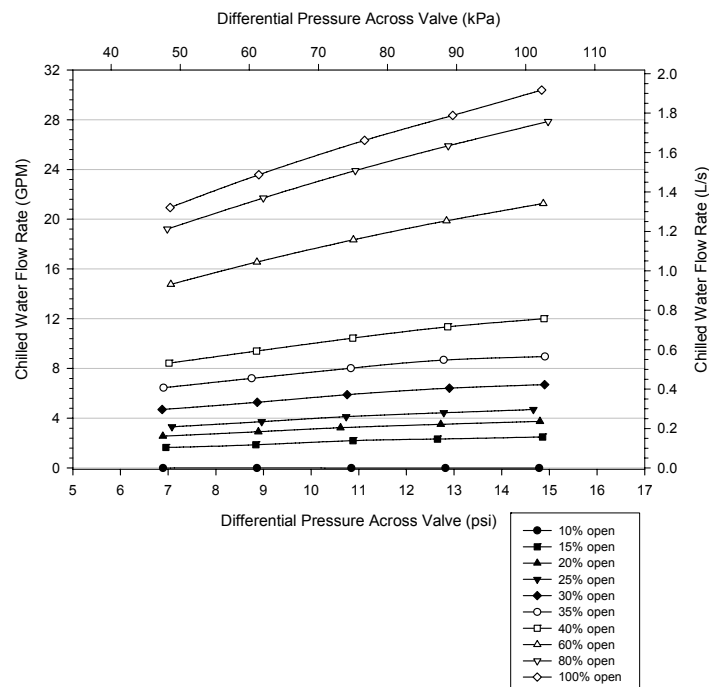

Figure 5-2: Flow rate through the globe valve as a function of differential pressure and commanded signal to the valve. (Chilled Water Cooling Coil Application – Globe Valve)

## Results

Figure 5-3 shows a comparison of the flow rate through the Belimo PICCV and globe valve as a function of the scaled feedback signal from each valve at a differential pressure of 7 psi (48.3 kPa). This plot is similar to Figure 2-6. Once again the Belimo valve was found to have the characteristic of an equal percentage valve, whereas the globe valve demonstrated a nearly linear flow characteristic.

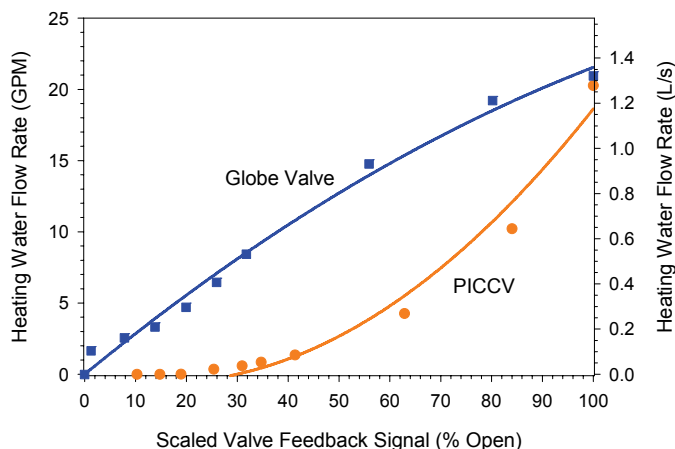

Figure 5-3: Flow rate through the Belimo PICCV and globe valve as a function of the scaled valve feedback signal at a differential pressure of 7 psi

## Results

Figure 5-3 shows a comparison of the flow rate through the Belimo PICCV and globe valve as a function of the scaled feedback signal from each valve at a differential pressure of 7 psi (48.3 kPa). This plot is similar to Figure 2-6. Once again the Belimo valve was found to have the characteristic of an equal percentage valve, whereas the globe valve demonstrated a nearly linear flow characteristic.

### Air-Handling Unit Chilled Water Open Loop Test Conclusions:

Open-loop tests were conducted to quantify the water flow rate through a Belimo PICCV-32-026-PT and a correctly sized globe valve as a function of differential pressure across the valve and the commanded signal to the valve.

### 5-2. Air-Handling Unit Chilled Water Open Loop Test Conclusions:

Consistent with the manufacturer's literature, for the differential pressure range of 7 to 15 psi that was tested, the flow rate through the Belimo PICCV was nearly independent of differential pressure for a fixed valve position. As expected, the flow rate through the globe valve increased as the differential pressure increased for a fixed valve position; however, the flow rate through the globe valve with the valve fully open was 21% lower than expected based on the manufacturer's literature.

Based on actual measurements, the globe valve has a flow coefficient of 7.9, which falls between the recommended valve size calculated assuming a 4 psi pressure drop across the valve ( $C_v = 10.5$ ), and the size calculated using ASHRAE sizing criteria ( $C_v = 6.8$ ). Thus, the globe valve should control better than the "correctly" sized valve used in the terminal reheat application, which turned out to be oversized by both sizing criteria. Testing also revealed that the Belimo valve has an equal percentage characteristic curve, while the globe valve has a nearly linear characteristic curve.

## 6.0 Air-Handling Unit Chilled Water Closed Loop Test – Control Performance

The purpose of this suite of tests was to compare the control performance of the Belimo PICCV to a conventional globe valve for a chilled water cooling coil application. The test evaluated various control characteristics, such as stability and ability to maintain the supply air temperature at the setpoint, as scheduled disturbances were imposed on the cooling coil and control valve.

## Results

Figures 6-1 and 6-2 are plots of the control (commanded) and scaled feedback signals to the valves, respectively. The response of the Belimo PICCV to the setpoint and pressure changes is evident in the plots. Decreases in the control signal are associated with increases in the supply air temperature setpoint and increases in the primary chilled water pump speed, whereas increases in the control signal are associated with reductions in the primary chilled water pump speed. The PICCV has a stable control and feedback signal over the entire test. The globe valve exhibits stable control initially; however, as the valve approaches a fully closed position, the control signal begins to oscillate. The feedback signal for the globe valve captures the oscillations initially, however, it indicates the valve is essentially closed from hour five forward (there is little or no change in the feedback signal), which corresponds to a supply air temperature of 68°F (20°C).

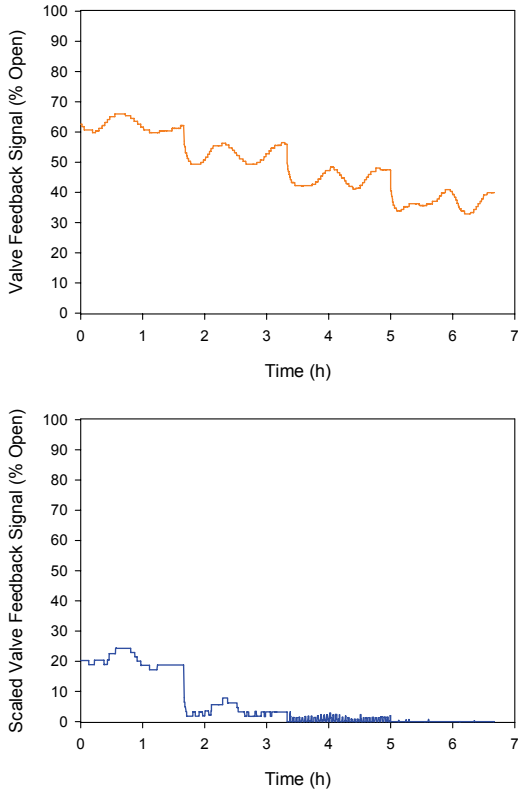

Figure 6-1: Chilled water cooling coil valve control signal.

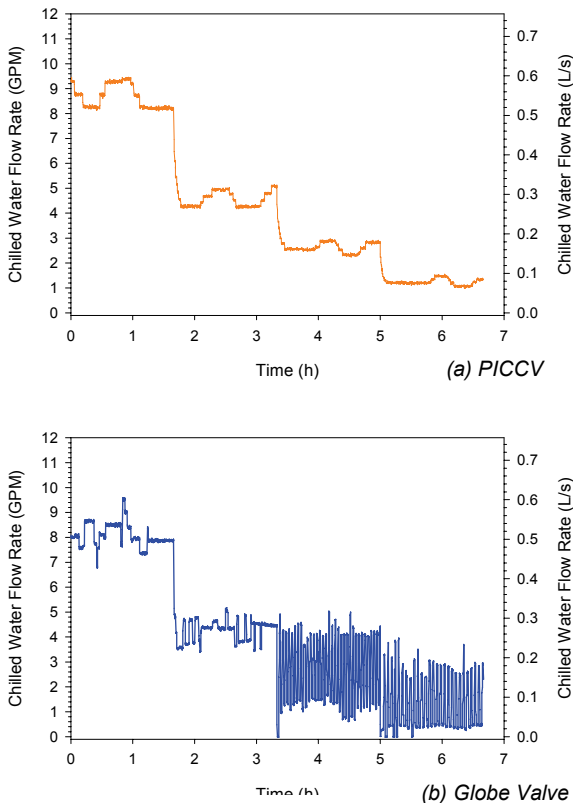

Figure 6-2: Chilled water cooling coil valve feedback signal.

Figures 6-3a and 6-3b are plots of the chilled water flow rate and supply air temperature control for the test. Figure 6-3a shows that the Belimo PICCV provides stable flow throughout the test, including flow rates as low as 0.99 GPM. This leads to stable control of the supply air temperature with one or two minor overshoots and undershoots at each setpoint value. On the other hand, it can be seen in Figure 6-3b that the flow through the globe valve is very unstable at flow rates below 4 GPM. The impact of unstable flow rate can be seen in the supply air temperature control. The supply air temperature corresponding to the globe valve oscillates significantly at the low load conditions simulated by increasing the supply air temperature setpoint to 64°F and then 68°F. Finally, although the feedback signal from the globe valve indicates it is essentially closed at a supply air temperature setpoint of 68°F, Figures 6-3b and 6-3a prove that the valve position is changing during this period because the chilled water flow rate and supply air temperature are obviously changing.

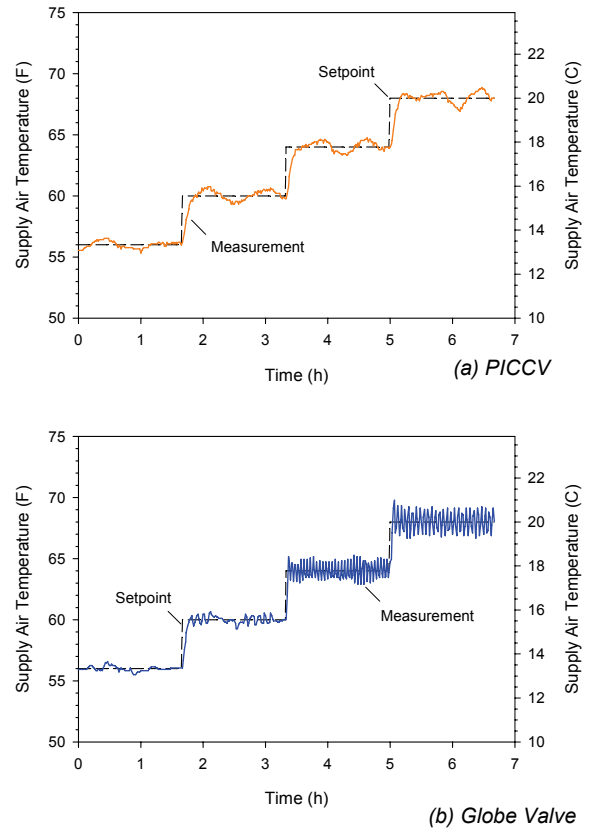

Figure 6-3: Chilled water flow.

## Results

Parameters in *Figures 6-4 through 6-6* reveal that the Belimo PICCV has a superior control performance to the globe valve. Note that the globe actuator travel, starts and stops, and reversals all plateau near the end of the test. This is because the calculation of these parameters is based on the feedback signal and the globe feedback signal indicates the valve is essentially closed from hour five forward. Nonetheless, the control performance parameters corresponding to the Belimo PICCV are smaller than those of the globe valve, indicating superior performance by the PICCV. For instance, the Belimo PICCV has **37% less actuator travel** and **nearly six times fewer reversals** than the globe valve. The cumulative change in the water flow rate is calculated directly from measurements of the flow rate and, therefore, is not affected by the valve feedback signal. The change in water flow rate of the globe valve is more than **four times** that of the Belimo PICCV.

## Results

Improved control at low flow rates observed for the Belimo PICCV is expected to lead to a higher temperature rise on average across the chilled water cooling coil, and a lower chilled water flow rate on average through the coil. Lower chilled water flow rates result in lower pumping energy. The temperature rise across the cooling coil is shown in *Figure 6-6*. The chilled water flow rate, averaged at 25 minute intervals (i.e., every 25 minutes, a new average is computed based on the previous 25 minutes of data), is shown in *Figure 6-6*. The secondary pumping power is shown in *Figure 6-7*. The plots in *Figure 6-6* indicate that the cooling coil equipped with the PICCV has a higher temperature rise across the cooling coil over the second half of the test, which corresponds to low load (i.e., low flow rates) conditions.

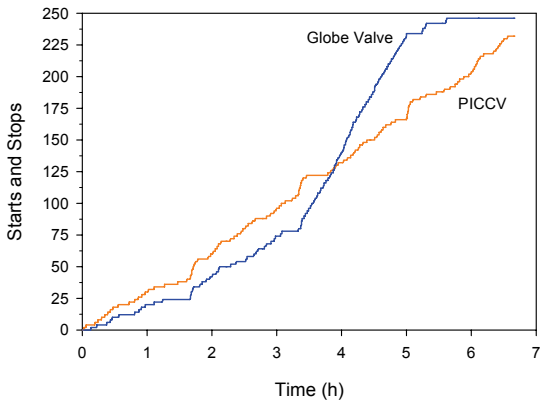

Figure 6-4: Accumulated starts and stops

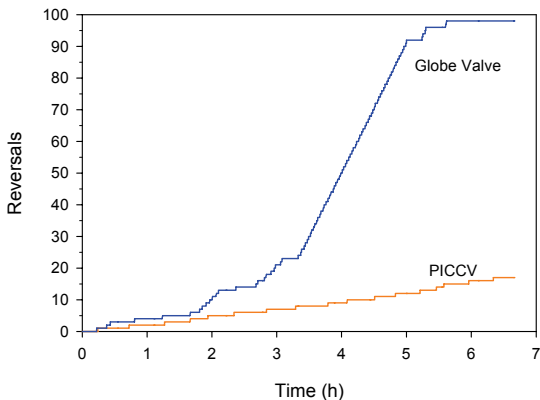

Figure 6-5: Accumulated Reversals

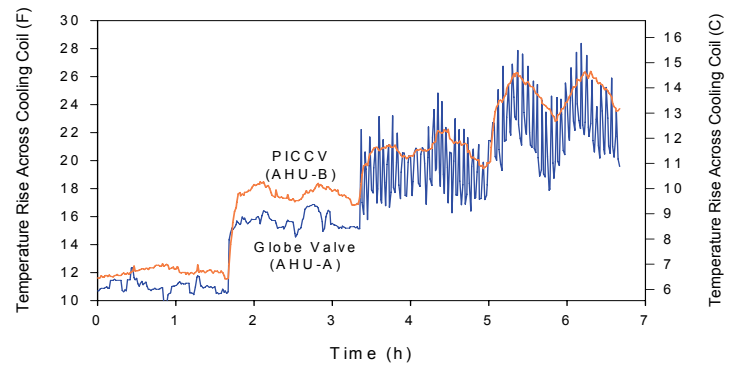

Figure 6-6: Temperature rise across the chilled water cooling coil

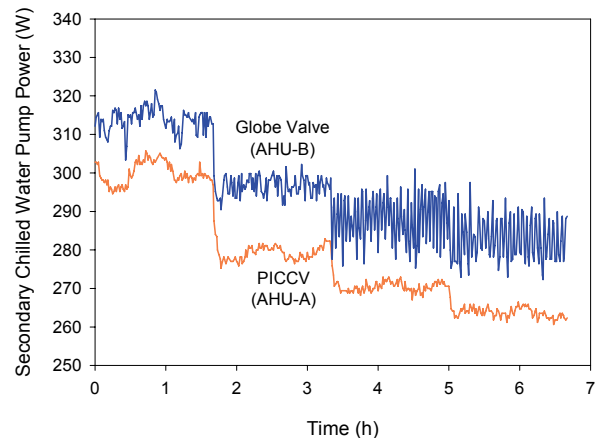

Figure 6-7: Secondary chilled water pump power

