



### Application

The Pressure Independent Characterized Control Valve is typically used in air handling units on heating and cooling coils, and fan coil unit heating or cooling coils. Some other common applications include unit ventilators and VAV re-heat coils. This valve is suitable for use in a hydronic system with constant or variable flow.

This valve is designed with MFT functionality which facilitates the use of various control input.

Technical Data	
Service	chilled or hot water, 60% glycol
Flow characteristic	equal percentage
Size	1¼", 1½", 2"
Type of end fitting	female, NPT
Materials	
Body	forged brass, nickel plated
Ball	chrome plated brass
Stem	chrome plated brass
Seat O-rings	Viton
Seat	fiberglass reinforced Teflon® PTFE
Characterizing disc	TEFZEL®
Packing	2 EPDM O-rings, lubricated
Diaphragm	polyester reinforced silicone
Regulator components	stainless steel/brass/Delrin 500 AF
Spring	stainless steel
Body pressure rating	400 PSI
Media temp. range	0°F to 212°F [-18°C to 100°C]
Close-off pressure	200 PSI
Leakage	ANSI Class IV (0.01% of rated valve capacity at 50 psi differential)
Flow rate	
1¼"	18 GPM [1.14 l/s], 19 GPM (1.2 l/s), 20 GPM [1.26 l/s], 21 GPM (1.32 l/s) 22 GPM [1.33 l/s], 23 GPM (1.45 l/s), 24 GPM [1.51 l/s], 25 GPM (1.58 l/s) 26 GPM [1.64 l/s]
1½"	26 GPM [1.64 l/s], 27 GPM (1.7 l/s), 28 GPM [1.77 l/s], 29 GPM (1.83 l/s) 30 GPM [1.89 l/s], 31 GPM (1.96 l/s), 32 GPM (2.01 l/s), 33 GPM [2.08 l/s]
2" small	33 GPM [2.08 l/s], 34 GPM (2.15 l/s), 35 GPM (2.21 l/s), 36 GPM [2.27 l/s], 37 GPM (2.33 l/s), 38 GPM (2.40 l/s), 39 GPM (2.56 l/s), 40 GPM [2.52 l/s]
2" large	44 GPM [2.78 l/s], 48 GPM [3.03 l/s], 52 GPM [3.28 l/s], 56 GPM [3.53 l/s], 60 GPM [3.79 l/s], 65 GPM [4.10 l/s], 70 GPM [4.42 l/s], 75 GPM [4.73 l/s], 80 GPM [5.05 l/s], 90 GPM [5.68 l/s], 100 GPM [6.31 l/s]
Rangeability	100 : 1
Differential pressure	5 to 50 PSI operating range
Valve accuracy	± 10% combination of manufacturing tolerances and pressure variations
Weight of valve body	1¼" = 8.31 lbs 1½" = 7.70 lbs 2" = 9.38 lbs 2" large = 29.10 lbs

2" body has two different flow capacities (44 GPM to 80 GPM) (90 GPM & 100 GPM)  
Tefzel® and Teflon® are registered trademarks of Dupont

Valve Model	Flow Rate		Valve Nominal Size			Suitable Actuators	
	GPM	Liter/sec	Inches	DN mm	Close-off PSI	Spring Return	Non-Spring Return
PICCV-32-018	18	1.14	1¼	32	200	AF24-MFT US	ARX24-MFT
PICCV-32-019	19	1.20	1¼	32	200		
PICCV-32-020	20	1.26	1¼	32	200		
PICCV-32-021	21	1.32	1¼	32	200		
PICCV-32-022	22	1.39	1¼	32	200		
PICCV-32-023	23	1.45	1¼	32	200		
PICCV-32-024	24	1.51	1¼	32	200		
PICCV-32-025	25	1.58	1¼	32	200		
PICCV-32-026	26	1.64	1¼	32	200		
PICCV-40-026	26	1.64	1½	40	200		
PICCV-40-027	27	1.70	1½	40	200		
PICCV-40-028	28	1.77	1½	40	200		
PICCV-40-029	29	1.83	1½	40	200		
PICCV-40-030	30	1.89	1½	40	200		
PICCV-40-031	31	1.96	1½	40	200		
PICCV-40-032	32	2.01	1½	40	200		
PICCV-40-033	33	2.08	1½	40	200		
PICCV-50-033	33	2.08	2	50	200		
PICCV-50-034	34	2.15	2	50	200		
PICCV-50-035	35	2.21	2	50	200		
PICCV-50-036	36	2.27	2	50	200		
PICCV-50-037	37	2.33	2	50	200		
PICCV-50-038	38	2.40	2	50	200		
PICCV-50-039	39	2.46	2	50	200		
PICCV-50-040	40	2.52	2	50	200		
PICCV-50-044	44	2.78	2	50	200		
PICCV-50-048	48	3.03	2	50	200		
PICCV-50-052	52	3.28	2	50	200		
PICCV-50-056	56	3.53	2	50	200		
PICCV-50-060	60	3.79	2	50	200		
PICCV-50-065	65	4.10	2	50	200		
PICCV-50-070	70	4.42	2	50	200		
PICCV-50-075	75	4.73	2	50	200		
PICCV-50-080	80	5.05	2	50	200		
PICCV-50-090	90	5.68	2	50	200		
PICCV-50-100	100	6.31	2	50	200		

L30037 - 05/09 - Subject to change. © Belimo Aircontrols (USA), Inc.



**MFT**



## Models

ARX24-MFT

Technical Data	
Power supply	24 VAC ± 20% 50/60 Hz 24 VDC ± 10%
Power consumption	running 4 W holding 1.25 W
Transformer sizing	6 VA (class 2 power source)
Electrical connection	½" conduit connector 18 GA plenum rated cable 3 ft [1m]
	ARB24-MFT ARX24-MFT □ 3 ft [1m] □ 10 ft [3m] □ 16 ft [5m]
Overload protection	electronic throughout 0° to 95° rotation
Operating range Y	2 to 10 VDC, 4 to 20 mA (default) Variable (VDC, PWM, Floating Point, On/Off)
Input impedance	100 kΩ (0.1 mA), 500 Ω 1500 Ω (PWM, Floating Point, On/Off)
Feedback output U	2 to 10 VDC, 0.5 mA max VDC Variable
Angle of rotation	95° electronically variable
Direction of rotation	reversible with protected  switch
Position indication	handle
Manual override	external push button
Running time	ARB24-MFT 100 seconds
Humidity	5 to 95% RH non-condensing (EN 60730-1)
Ambient temperature	-22°F to 122°F [-30°C to 50°C]
Storage temperature	-40°F to 176°F [-40°C to 80°C]
Housing	NEMA 2/IP54
Housing material	UL94-5VA
Agency listings†	cULus acc. to UL60730-1A/-2-14, CAN/CSA E60730-1, CSA C22.2 No. 24-93, CE acc. to 89/336/EEC
Noise level	<45 dB(A)
Quality standard	ISO 9001

† Rated impulse voltage 4kV, Control pollution degree 3, Type of action 1

### Dimensions with PICCV

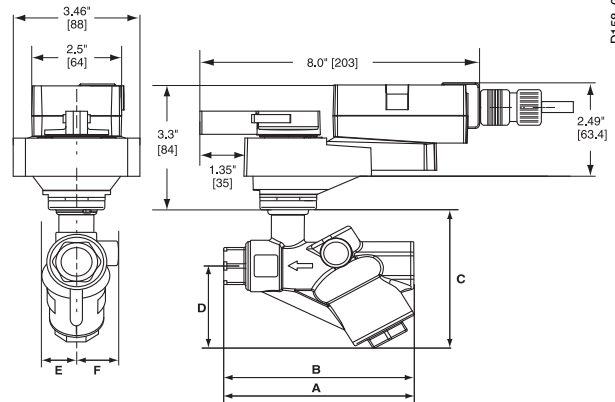

D158\_09

Valve  
Nominal  
Size

Dimensions (Inches [mm])

In.	DN [mm]	A	B	C	D	E	F
1¼"	32	8.19 [208]	8.19 [208]	5.67 [144]	3.66 [93]	1.77 [45]	1.61 [41]
1½"	40	8.03 [204]	8.03 [204]	5.67 [144]	3.66 [93]	1.77 [45]	1.61 [41]
2"	50	8.50 [216]	8.50 [216]	5.91 [150]	3.66 [93]	1.77 [45]	1.61 [41]

2" NPT with flows to 40 GPM.

### Dimensions with PICCV P/T Ports

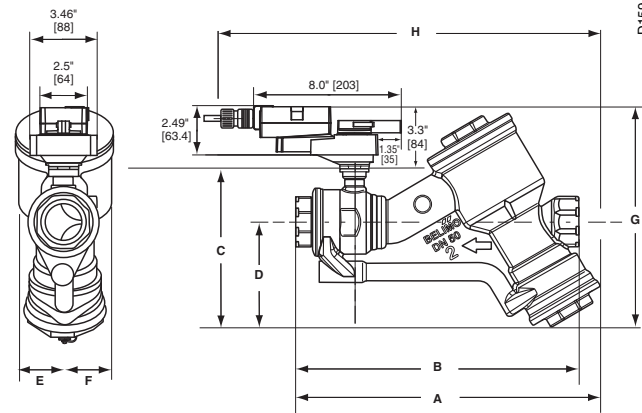

D159\_09

Valve  
Nominal  
Size

Dimensions (Inches [mm])

In.	DN [mm]	A	B	C	D
2"	50	16.39 [416]	15.60 [396]	8.94 [227]	5.87 [149]

Valve  
Nominal  
Size

Dimensions (Inches [mm])

In.	DN [mm]	E	F	G	H
2"	50	2.64 [67]	2.64 [67]	12.83 [326]	21.90 [556]

2" NPT with larger flows from 44 GPM to 100 GPM

L30037 - 05/09 - Subject to change. © Belimo Aircontrols (USA), Inc.

**Wiring Diagrams**

**INSTALLATION NOTES**

- 2** **CAUTION Equipment damage!**  
Actuators may be connected in parallel.  
Power consumption and input impedance must be observed.
- 3** Actuators may also be powered by 24 VDC.
- 4** Position feedback cannot be used with Triac sink controller.  
The actuator internal common reference is not compatible.
- 6** Control signal may be pulsed from either the Hot (source) or the Common (sink) 24 VAC line.
- 8** Contact closures A & B also can be triacs.
- 9** For triac sink the common connection from the actuator must be connected to the hot connection.

**APPLICATION NOTES**

- ◆** The ZG-R01 500 Ω resistor converts the 4 to 20 mA control signal to 2 to 10 VDC, up to 2 actuators may be connected in parallel.

**WARNING Live Electrical Components!**

During installation, testing, servicing and troubleshooting of this product, it may be necessary to work with live electrical components. Have a qualified licensed electrician or other individual who has been properly trained in handling live electrical components perform these tasks. Failure to follow all electrical safety precautions when exposed to live electrical components could result in death or serious injury.

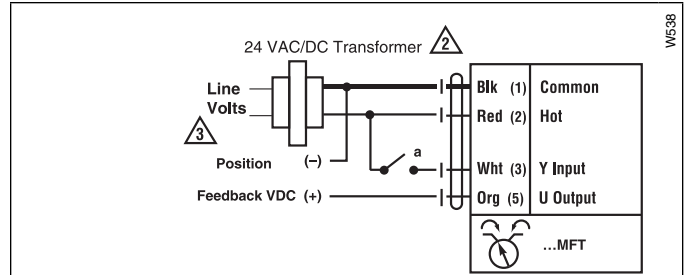

**On/Off control**

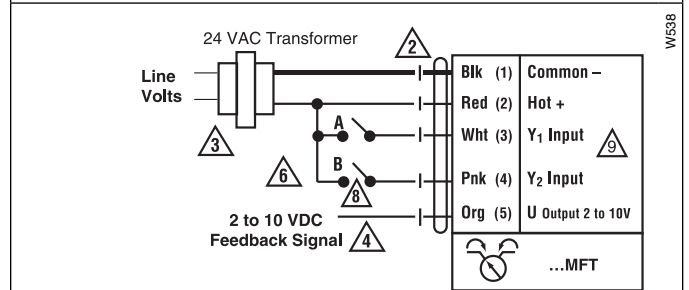

**Floating Point**

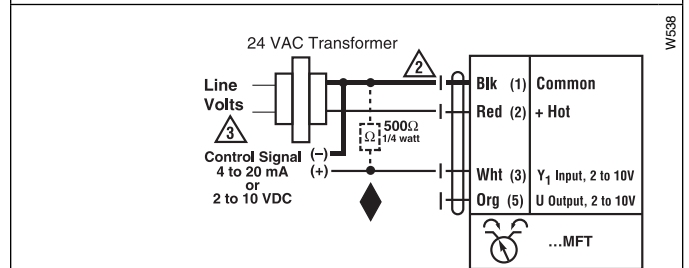

**VDC/4-20 mA**

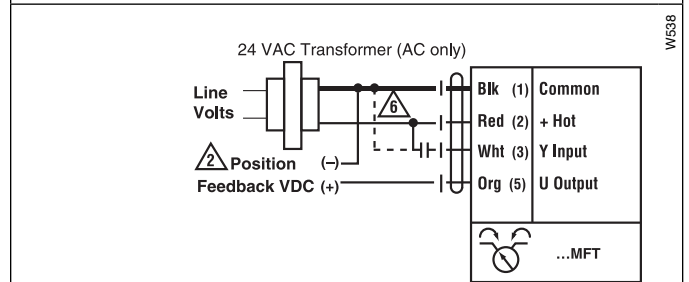

**PWM**