

P2... Series Pressure Independent Characterized Control Valves™ (PICCV) Chrome Plated Brass Ball and Brass Stem, NPT Female Ends



Application

The Pressure Independent Characterized Control Valve is typically used in air handling units on heating and cooling coils, and fan coil unit heating or cooling coils. Some other common applications include unit ventilators and VAV re-heat coils. This valve is suitable for use in a hydronic system with constant or variable flow.

This valve is designed with MFT functionality which facilitates the use of various control input.

Technical Data	
Service	chilled or hot water, 60% glycol
Flow characteristic	equal percentage
Size	½", ¾", 1"
Type of end fitting	female, NPT
Materials	
Body	forged brass, nickel plated
Ball	chrome plated brass
Stem	chrome plated brass
Seat O-rings	Viton
Seat	fiberglass reinforced Teflon® PTFE
Characterizing disc	½" & ¾" Brass 1" TEFZEL®
Packing	2 EPDM O-rings, lubricated
Diaphragm	½" & ¾" silicone and Nomex 1" polyester reinforced silicone
Regulator components	stainless steel/brass/Delrin 500 AF
Spring	stainless steel
Body pressure rating	600 PSI
Media temp. range	0°F to 212°F [-18°C to 100°C]
Close off pressure	200 PSI
Leakage	ANSI Class IV (0.01% of rated valve capacity at 50 psi differential)
Flow rate	
½"	0.5 GPM [.03 l/s], 1 GPM [.06 l/s], 1.50 GPM [0.09 l/s], 2 GPM [.13 l/s], 2.5 GPM (0.16 l/s) , 3 GPM [.19 l/s], 3.5 GPM (0.22 l/s), 4 GPM [.25 l/s], 4.5 GPM (0.28 l/s), 5 GPM [.32 l/s], 5.5 GPM (0.35 l/s)
¾"	6 GPM [0.37 l/s], 6.5 GPM (0.41 l/s), 7 GPM [0.44 l/s], 7.5 GPM (0.47 l/s) 8 GPM [0.50 l/s], 8.5 GPM (0.54 l/s), 9 GPM [0.57 l/s], 9.5 GPM (0.60 l/s) 10 GPM [0.63 l/s]
1"	11 GPM (0.69 l/s), 12 GPM [0.76 l/s], 13 GPM (0.82), 14 GPM [0.88 l/s], 15 GPM (0.95 l/s), 16 GPM [1.01 l/s], 17 GPM (1.07 l/s), 18 GPM [1.14 l/s] 19 GPM (1.20 l/s)
Rangeability	100 : 1
Differential pressure	5 to 50 PSI operating range
Valve accuracy	± 10% combination of manufacturing tolerances and pressure variations
Weight of valve body	½" = 2.52 lbs ¾" = 2.52 lbs 1" = 4.98 lbs

½" body has two different flow capacities (.50 GPM to 2.5 GPM) (3 GPM to 5.5 GPM)
1" body has two different flow capacities (11 GPM to 16 GPM) (17 GPM to 19 GPM)
Tefzel® and Teflon® are registered trademarks of Dupont

Valve Model	Flow Rate		Valve Nominal Size		Suitable Actuators		
	GPM	Liter/sec	Inches	DN mm	Close-off PSI	Spring Return	Non-Spring Return
P2050B005	0.5	0.03	½	15	200	TF24-MFT US	
P2050B010	1	0.06	½	15	200		
P2050B015	1.5	0.09	½	15	200		
P2050B020	2	0.13	½	15	200		
P2050B025	2.5	0.16	½	15	200		
P2050B030	3	0.19	½	15	200		
P2050B035	3.5	0.22	½	15	200		
P2050B040	4	0.25	½	15	200		
P2050B045	4.5	0.28	½	15	200		
P2050B050	5	0.32	½	15	200		
P2050B055	5.5	0.35	½	15	200	LF24-MFT US LRB(X)24-3 LRX24-MFT LRCB24-3 Heat Pump Only	
P2075B060	6	0.38	¾	20	200		
P2075B065	6.5	0.41	¾	20	200		
P2075B070	7	0.44	¾	20	200		
P2075B075	7.5	0.47	¾	20	200		
P2075B080	8	0.50	¾	20	200		
P2075B085	8.5	0.54	¾	20	200		
P2075B090	9	0.57	¾	20	200		
P2075B095	9.5	0.60	¾	20	200		
P2075B100	10	0.63	¾	20	200		
PICCV-25-011	11	0.69	1	25	200		
PICCV-25-012	12	0.76	1	25	200		
PICCV-25-013	13	0.82	1	25	200		
PICCV-25-014	14	0.88	1	25	200		
PICCV-25-015	15	0.95	1	25	200		
PICCV-25-016	16	1.01	1	25	200		
PICCV-25-017	17	1.07	1	25	200		
PICCV-25-018	18	1.14	1	25	200		
PICCV-25-019	19	1.20	1	25	200		

L30037 - 05/09 - Subject to change. © Belimo Aircontrols (USA), Inc.



Models

TF24-MFT US

Technical Data	
Control	MFT
Power supply	24 VAC ± 20% 50/60 Hz 24 VDC ± 10%
Power consumption	running 2.5 W holding 1.0 W
Transformer sizing	4 VA (class 2 power source)
Electrical connection	3 ft, 18 GA plenum rated cable ½" conduit connector
Overload protection	electronic throughout 0° to 95° rotation
Operating range Y*	2 to 10 VDC 4 to 20 mA (w/500 Ω, ¼ W resistor) ZG-R01
Input impedance	100k Ω for 2 to 10 VDC (0.1 mA) 500 Ω for 4 to 20 mA 1500 Ω for PWM, Floating point and On-Off control
Feedback output U*	2 to 10 VDC, 0.5 mA max
Direction of rotation	spring reversible with CW/CCW mounting motor reversible with built-in ↻/↻ switch
Mechanical angle of rotation*	95°
Running time	motor* 100 seconds spring <25 sec @ -4°F to 122°F [-20°C to 50°C] <60 sec @ -22°F [-30°C]
Angle of Rotation Adaptation*	Off (Default)
Override control*	Min. (Min Position) = 0% - ZS (Mid. Position) = 50% - Max. (Max. Position) = 100%
Position indication	visual indicator, 0° to 95°
Humidity	5 to 95% RH, non-condensing
Ambient temperature	-22 to 122° F (-30 to 50° C)
Storage temperature	-40 to 176° F (-40 to 80° C)
Housing	NEMA 2/IP42
Housing material	UL 94-5VA
Noise level (max)	running <35 dB (A) spring return <65 dB (A)
Agency listings†	cULus acc. to UL60730-1A/-2-14, CAN/CSA E60730-1, CSA C22.2 No.24-93, CE acc to 89/336/EEC
Quality standard	ISO 9001

* Variable when configured with MFT options

† Rated impulse voltage 0.8 kV, Control pollution degree 3, Type of action 1.AA.

Dimensions with PICCV

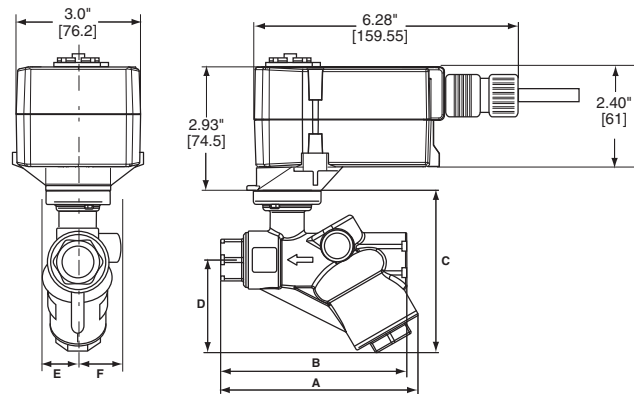

D189

Valve
Nominal
Size

Dimensions (Inches [mm])

In.	DN [mm]	A	B	C	D	E	F
½"	15	4.68 [119]	4.47 [114]	4.05 [103]	2.34 [60]	0.99 [25]	0.99 [25]

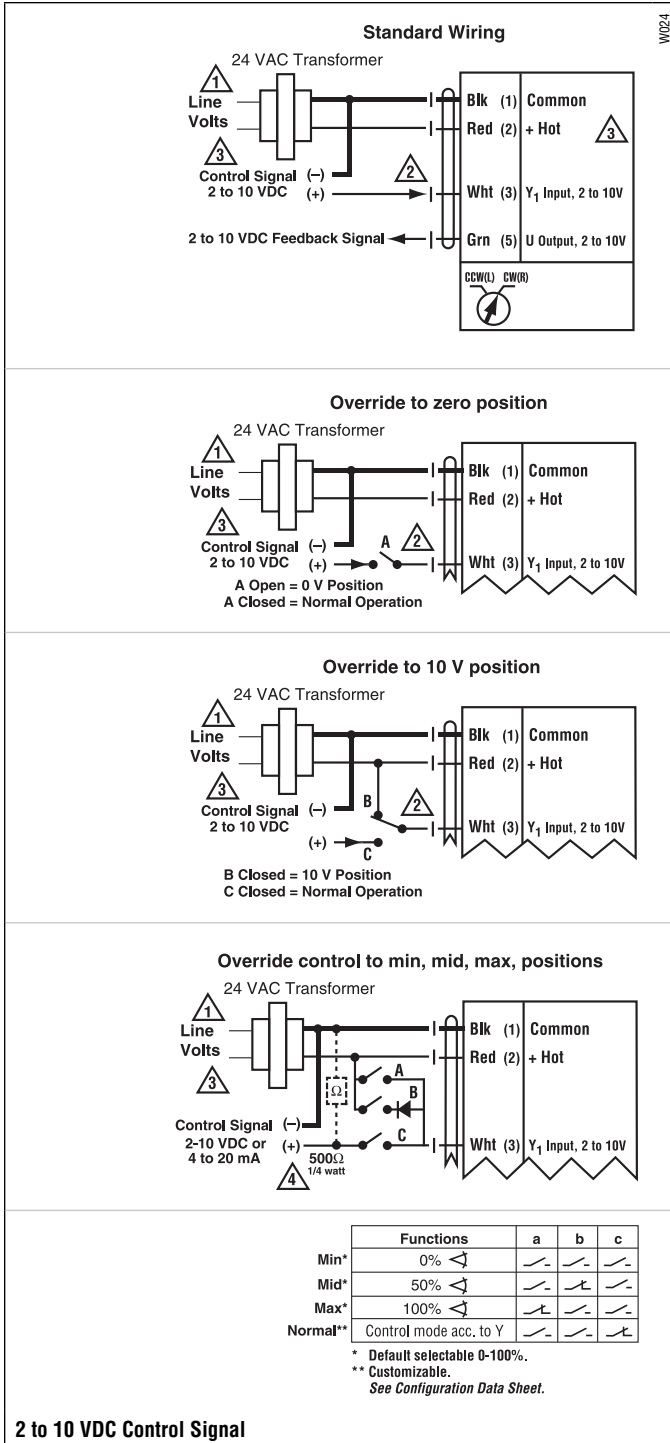

L30037 - 05/09 - Subject to change. © Belimo Aircontrols (USA), Inc.

Wiring Diagrams

INSTALLATION NOTES

- 1 Provide overload protection and disconnect as required.
- 2 **CAUTION Equipment damage!** Actuators may be connected in parallel. Power consumption and input impedance must be observed.
- 3 Actuators may also be powered by 24 VDC.
- 4 ZG-R01 may be used.

WARNING Live Electrical Components! During installation, testing, servicing and troubleshooting of this product, it may be necessary to work with live electrical components. Have a qualified licensed electrician or other individual who has been properly trained in handling live electrical components perform these tasks. Failure to follow all electrical safety precautions when exposed to live electrical components could result in death or serious injury.

